



DEVELOPMENT STANDARD

QIC-148
Revision D
20 Jun 96

UNRECORDED MAGNETIC TAPE MINICARTRIDGE FOR INFORMATION INTERCHANGE

0.315 inch (8.0 mm), 3.5-inch form factor
50 800 fpi (2000 ftpmm)
900 Oersteds (72 000 amperes/meter)

Intended for use with the following recording format:

QIC-3010-MC	425 MBytes
QIC-3020-MC	850 MBytes
QIC-3040-MC	1.0 GBytes
QIC-3080-MC	2.0 GBytes
QIC 3095-MC	2.1 GBytes

**Quarter-Inch
Cartridge
Drive Standards, Inc.**

311 East Carrillo Street
Santa Barbara, California 93101
Telephone (805) 963-3853
Fax (805) 962-1541
www.qic.org

(See important notices on the following page)

Revision History

Revision	Change Document	Date
Revision A	QIC-148	1 September 1993
Revision B	QIC-94-94A	14 December 1994
Revision C	QIC-95-90	30 August 1995
Revision D	QIC-96-23A Removes section 5.8 - Stiffness Removes section 5.10 - Poisson's Ratio	20 June 1996

TABLE OF CONTENTS

1.0 INTRODUCTION	1
1.1 Scope.....	1
1.3 Conformance.....	1
2.0 REFERENCES	2
3.0 DEFINITIONS	2
4.0 ENVIRONMENT AND SAFETY	4
4.1 Testing Environment.....	4
4.2 Operating Environment.....	4
4.3 Transportation Environment.....	4
4.4 Storage Environment.....	4
4.5 Conditioning of the Cartridge.....	5
4.6 Safety.....	5
5.0 TAPE MECHANICAL AND ELECTRICAL PROPERTIES	5
5.1 Tape Width and Tolerance.....	5
5.2 Tape Length.....	5
5.3 Tape Thickness.....	5
5.4 Tape Position Holes.....	5
5.5 Leaders and Splices.....	6
5.6 Tape Wind.....	6
5.7 Tensile Yield Force.....	6
5.8 Young's Modulus.....	6
5.9 Transverse Dimensional Stability.....	6
5.10 Electrical Resistance.....	6
5.11 Layer-to-Layer Adhesion.....	7
5.12 Tape Cupping.....	7
5.13 Tape Light Transmission.....	8
6.0 TAPE RECORDING PROPERTIES	8
6.1 Defect Density.....	9
6.2 Average Signal Amplitude.....	9
6.3 Signal Decay.....	10
6.4 Resolution.....	10
6.5 Typical Field.....	10
7.0 MECHANICAL SPECIFICATIONS OF THE TAPE CARTRIDGE	10
7.1 General Description.....	10
7.2 File Protect.....	11
7.3 Physical Labels.....	11
7.4 Tape Guides.....	11
7.5 Speeds.....	11
7.6 Driving Force.....	11
7.7 Total Inertia.....	12
7.8 Dynamic Response.....	12

7.9 Tape Tension	12
7.10 Drive Ratio.....	14
7.11 Belt Capstan Electrical Resistance.....	14
7.12 Instantaneous Speed Variation (ISV).....	15
7.13. Acceleration.....	16
7.14 Dynamic Tape Skew.....	16
7.15 Drop Test.	16
7.16 Head Penetration.....	17
7.17 Dynamic Track Movement Variation.....	17
7.18 Tape Slope.....	17

LIST OF FIGURES

Figure 1 - Possible cartridge configuration.....	18
Figure 2 - Tape position hole.....	19
Figure 2A - Tape position hole.....	20
Figure 2B - Tape position hole.....	21
Figure 3 - Tape resistance measurement electrodes.....	22
Figure 4 - Tape resistance measurement circuit.....	22
Figure 5 - Cartridge Dimensions.....	23
Figure 6 - Cartridge locating planes.....	24
Figure 7 - Light sensing.....	25
Figure 8 - File protect and cartridge-in-position sense.....	26
Figure 9 -Cartridge door profile.....	27
Figure 10 - Label area.....	28
Figure 11-Tape path and drive dimensions.....	29
Figure 12 - Tape light transmission test fixture.....	30
Figure 13 - Tape light transmission test circuit.....	31
Figure 14 - Transverse tape tension test rod.....	32
Figure 15 - Belt capstan electrical resistance test fixture.....	33

1.0 INTRODUCTION

1.1 Scope. This standard provides the information necessary to ensure mechanical and magnetic interchangeability for a tape cartridge between information processing systems, communication systems, and associated equipment. This standard provides the general requirements, definitions, physical and magnetic tape characteristics, and the cartridge requirements.

1.2 Purpose. This standard defines the requirements and supporting test methods necessary to ensure interchange at acceptable performance levels. It is distinct from a specification in that it delineates a minimum of restrictions consistent with compatibility in interchange transactions.

The performance levels in this standard represent the minimum acceptable levels that the interchanged items should meet or surpass during their useful life and, thus, define end-of-life criteria for interchange purposes. The performance levels in this standard are not intended to be employed as substitutes for purchase specifications. Wherever feasible, quantitative performance levels that must be met or exceeded in order to comply with this standard, are given. In all cases, including those in which quantitative limits for requirements falling within the scope of this standard are not stated but left to agreement between the interchange parties, standard test methods and measurement procedures shall be used to determine such limits.

The original dimensions and quantities for all numeric values in this standard are in U.S. Customary engineering units (similar to British Imperial units) and centimeter-gram-second electromagnetic units (cgs-emu). Conversions of these units to the International System of Units (SI) have been incorporated in accordance with the procedures described in American National Standard Metric Practice, ANSI/IEEE 268-1982. Units of either of the two measurement systems may be referred to, but the two systems should not be intermixed or reconverted. Conversions of toleranced dimensions and quantities in this standard have been performed in accordance with Method A or Method B of ANSI/IEEE 268-1982 and International Standard Toleranced Dimensions Conversions from inches into millimeters and vice versa, ISO 370:1975 as required to maintain the implied correspondence between the accuracy of the original data and the number of significant digits and rounding of the converted values. Method A has been used to achieve economy unless a requirement for absolute assurance of fit justified the use of Method B. Conversions made in accordance with Method B are so indicated. In the national standards of ISO member bodies, additional rounding may be done to produce "preferred" values. These values should lie within or close to the original tolerance.

1.3 Conformance. A magnetic tape cartridge conforms to this standard if it satisfies all mandatory requirements of this standard. The tape requirements shall be satisfied throughout the extent of the tape.

2.0 REFERENCES

ANSI Y14.5M-1982 Engineering drawing and related documentation practices, dimensioning and tolerancing.

ANSI/IEEE 268-1982 Metric practice.

ISO-370:1975 Toleranced dimensions - conversions from inches into millimeters and vice versa.

UL94-V0 Underwriters Laboratory standard for safety-test for flammability of plastic materials, parts, devices and appliances.

3.0 DEFINITIONS

average signal amplitude. The average peak-to-peak value of the signal output of the read head over a minimum of 1.0 in (25.4 mm) exclusive of dropouts.

beginning-of-tape (BOT) marker. A set of two holes punched in the tape. Three sets of holes are provided to ensure reliability of detection. The innermost set of holes identifies the storage position for the cartridge. In the storage position, all of the useable recording area shall be wound on the supply hub and protected by at least one layer of tape. Cartridges to be interchanged shall be rewound to the storage position prior to interchange.

cartridge I.D. holes. A set of holes located between BOT 1 and BOT 2 holes to identify cartridge type as shown in Figure 2.

early warning (EW) marker. One hole punched in the tape to indicate the approaching end of the useable recording area in the forward direction of tape motion. Recording must halt before the EOT marker is detected.

end of tape (EOT) marker. A single hole punched in the tape to indicate that the useable recording area, when the tape is moving in the forward direction, has been exceeded. Three holes are provided along a single line, to ensure reliability of detection.

flux transition position. The point that exhibits the maximum free-space surface flux density normal to the tape surface.

in contact. An operating condition in which the magnetic surface of the tape is in physical contact with a magnetic head.

load point (LP) marker. A single hole punched in the tape to indicate the start of the useable recording area when tape motion is in the forward direction.

magnetic tape. A tape which will accept and retain magnetic signals intended for input, output, and storage purposes on computers and associated equipment.

master standard reference tape. A tape selected as a standard for amplitude, resolution and typical field.

NOTE: A master standard reference tape will be established for the physical recording density of 50 800 ftpi (2000 ftpmm). Secondary standard amplitude reference tapes are available from 3M under the part number xxxx. For ordering information contact: Local 3M Company Sales Representative for Data Storage Products.

physical recording density. The number of recorded flux transitions per unit length of track, e.g., flux transitions per inch (ftpi) or flux transitions per millimeter (ftpmm).

reference field. The typical field of the master standard reference tape.

resistance per square. The surface resistance of a square are, of any size, measured between electrodes placed on two opposite sides of the square. The unit of measurement is the ohm.

resolution. The ratio of the average signal amplitude measured at 50 800 ftpi (2000 ftpmm) to that measured at 16 933 ftpi (609 ftpmm).

secondary standard reference tape. A tape the performance of which is known and stated in relation to that of the master standard reference tape.

standard measurement current. For the test physical recording density, the standard measurement current (I_m) is 1.15 times the standard reference current (I_r) at 50 800 ftpi (2000 ftpmm). Write current overshoot shall be between 5% and 10% of the zero to peak value excluding the overshoot.

standard reference amplitude. The average peak-to-peak signal amplitude output from the master standard amplitude reference tape when it is recorded with the standard measurement current on the standard measurement system at the test physical recording density. The signal amplitude shall be averaged over at least 50 800 flux transitions. Traceability to the standard reference amplitude reference level is provided by the secondary amplitude reference tapes.

standard reference current. The minimum record current, which, when applied to a secondary standard amplitude reference tape at the test physical recording density, causes an average peak-to-peak signal amplitude output equal to 95 percent of the maximum signal amplitude output.

test recording current. The current that is 1.15 times the standard reference field.

tested recording area. That portion of the tape, as shown in Figure 2, that has been tested in accordance with 6.0.

track. A longitudinal area on the tape along which a series of magnetic signals may be recorded.

typical field. In the plot of average signal amplitude against the recording field at physical recording density of 50 800 fpi (2000 ftpmm) the minimum field that causes an average signal amplitude equal to 95% of the maximum average signal amplitude.

4.0 ENVIRONMENT AND SAFETY

4.1 Testing Environment. Tests and measurements made on the cartridge to check the requirements of this standard shall be carried out under the following conditions:

Temperature: 68°F ± 7°F (20°C ± 4°C)
Relative Humidity: 50% ± 10%
Condition before Testing: 24 hours
Maximum Dewpoint Temperature: 64°F (18°C)

4.2 Operating Environment. Cartridges used for data interchange shall be capable of operating under the following conditions:

Temperature: 41°F ambient to 134°F baseplate
(5°C ambient to 57°C baseplate)
Relative Humidity: 20% to 80% noncondensing
Maximum Dewpoint Temperature: 84°F (29°C)

The operating environment temperature is to be measured in the air immediately surrounding the cartridge. Baseplate temperature shall be measured on the exterior surface within a 0.5 in (12.7 mm) radius of the belt capstan pin. Rapid temperature variations should be avoided. There shall be no deposit of moisture on or in the cartridge.

4.3 Transportation Environment. During transportation, the cartridge may be exposed to conditions outside the operating environment. The recommended safe limits are:

Temperature: -40°F to 126°F (-40°C to 52°C)
Relative Humidity: 20% to 80% noncondensing
Maximum Wet Bulb Temperature: 79°F (26°C)

If it is suspected that the cartridge has been subjected to mechanical shock simultaneously with exposure to cold, as evidenced by tape pack shift, the cartridge should be conditioned as described in 4.5.

4.4 Storage Environment.

Temperature: 23°F to 113°F (-5°C to 45°C)
Relative Humidity (RH): 20% to 80% noncondensing
Maximum Wet Bulb Temperature: 79°F (26°C)

Cartridges that have been exposed to temperatures above 113°F (45°C) may still be able to function usefully with a high probability of retrieving data stored on them. Under no circumstances should cartridges be exposed to temperatures in excess of 167°F (75°C) as permanent damage may occur. Whenever possible it is recommended that cartridges be stored in room environment conditions of 68°F +/- 9°F (20°C +/- 5°C), 50% +/- 20% RH.

4.5 Conditioning of the Cartridge. Before use the cartridge shall be conditioned by exposure to the operating environment for a time at least equal to the period during which it has been out of the operating environment (up to a maximum of 8 hours).

The cartridge shall also be conditioned by running the tape one complete end-to-end pass in any of the following cases:

- (1) Each time that it is inserted into a drive for test purposes in this standard.
- (2) After prolonged operation over a limited tape length (> 50 passes over any tape length less than the full tape length).
- (3) At the point when the cartridge has been exposed to a decrease in temperature of 30°F (16°C).

4.6 Safety

4.6.1 Safeness. The components of the tape and cartridge assembly shall not constitute any safety or health hazard when used in the intended manner, or through any foreseeable misuse in an information processing system.

4.6.2 Flammability. The materials used in the external cartridge covers must have a flammability rating of at least 94V-2, as described in the Underwriters Laboratory UL94 Standard for Safety-Test for Flammability of Plastic Materials, Parts, Devices and Appliances.

5.0 TAPE MECHANICAL AND ELECTRICAL PROPERTIES

5.1 Tape Width and Tolerance. The tape width shall be 0.3149 in +/- 0.0005in (8.000 mm +/- 0.013 mm).

5.2 Tape Length. The tape length between LP and EW markers shall be 400 ft + 25 ft, - 0 ft (122.0 m +8 m, - 0 m).

5.3 Tape Thickness. The overall thickness of the tape shall be 330 µin(8.4 µm) maximum.

5.4 Tape Position Holes. Tape position holes for beginning of tape, load point, early warning, and end of tape will be provided as shown in Figure 2 or Figure 2A. These position holes used as tape markers are symmetrically located to allow bidirectional tape control.

5.5 Leaders and Splices. The cartridge shall contain no splices or spliced-in leaders.

5.6 Tape Wind. The tape shall be wound on the hubs with the magnetic coating out, and in such a way that during forward read/write operations the tape is unwound in a clockwise direction viewed from the top of the cartridge as shown in Figure 1.

5.7 Tensile Yield Force.

5.7.1 Definition. The tensile yield force shall be taken as the force required to elongate the sample 3%.

5.7.2 Requirement. The tensile yield force at 3% elongation shall be minimum of 1.2 lbf (5.3 N).

5.7.3 Procedure. Use static weighting, constant rate-of-grip separation tester capable of indicating the load to an accuracy of +/- 2%. Clamp a specimen of tape at least 7 in (178 mm) in length, with an initial 4 in (102 mm) separation between the jaws. Elongate the specimen at a rate of 2 in (51 mm) per minute until the minimum elongation of 10% is reached. The force required to produce an elongation of 3% is the tensile yield force.

5.8 Young's Modulus - $> 0.9 \times 10^6$ psi (machine direction)

5.9 Transverse Dimensional Stability - 0.003 in/in within the operating environment.

5.10 Electrical Resistance.

5.10.1 Definition. Electrical resistance is defined as the resistance of the oxide coating and backside surface, measured in ohm per square.

5.10.2 Requirement. The resistance shall not exceed 5×10^{12} ohms per square, but shall be greater than 5×10^9 ohms per square for the oxide surface and the resistance shall not exceed 2×10^6 ohms per square for the backside surface.

5.10.3 Procedure. After 12 hours exposure to the test environment, two layers of the sample tape shall be placed back-to-back between the strip electrodes, as shown in Figures 3 and 4 such that the magnetic-oxide-coated sides are in contact with all of the electrodes. In mounting the specimen for measurement, it is important that no conducting paths exist between the electrodes except those through the specimen. To ensure that the length of tape held between each strip electrode is the same, the specimen shall be placed under 8 ozf +/- 2 ozf (2.23 N +/- 0.56 N) tension as it is being clamped.

NOTE: Neither the specimen nor the insulating surfaces shall be handled with the bare fingers. (The use of clean, lint-free gloves is recommended.)

Measurement shall be made between each pair of adjacent electrodes. This will produce a total of 5 readings per specimen. The resistance of the coating shall be determined by means of a guarded circuit, as shown in Figure 4, using 500 volt, +/- 10 volts, potential.

Average the five resistance readings.

5.11 Layer-to-Layer Adhesion

5.11.1 Definition. Layer-to-Layer adhesion refers to that property of a magnetic tape where in one layer when held in close proximity to the adjacent layer exhibits an adhesive nature and bonds itself to an adjacent layer so that free and smooth separation of the layers is difficult.

5.11.2 Requirement. There shall be no evidence of layer-to-layer adhesion or coating delamination.

5.11.3 Procedure. A 3 ft (914 mm) length of tape shall be fastened at one end, magnetic side down, to a 0.5 in (12.7 mm) diameter by a 4 in (102 mm) long stainless steel cylinder with a non-oozing adhesive material. Attach the opposite end of the tape to a 0.57 lb (260 g) weight. A small strip of double-coated adhesive tape shall be affixed to the magnetic side of the tape 1 in (25.4 mm) above the weight. The tube shall then be slowly and uniformly rotated so that the tape, held in tension by the weight, winds uniformly around the tube into a compact and even roll. The double-coated tape when wound into the roll acts to secure the end and prevent unwinding when the weight is removed. The tube supporting the weight is then exposed to the following temperature and humidity cycle:

<u>TIME (hr)</u>	<u>TEMPERATURE</u>	<u>RELATIVE HUMIDITY</u>
16-18	130°F (54.4°C)	85% +/- 5%
4	130°F (54.4°C)	10% or less
1-2	70°F (21.1°C)	45% +/- 5%

To evaluate the tape for adhesion, the end of the roll should be opened and the sticky tab removed. The free end of the tape should then be held and the cylinder allowed to fall, thereby unwinding the tape. The unwound tape should then be checked for coating delamination with the exception of the last 2 in (51 mm) of tape nearest the cylinder.

5.12 Tape Cupping

5.12.1 Definition. The departure across a tape (transverse to motion) from a flat surface is defined as cupping.

5.12.2 Requirement. The departure from a flat surface shall not exceed 0.032 in (0.81 mm).

5.12.3 Procedure. Cut a tape length of 0.315 in (8.0 mm) and place the cut tape concave side down on a flat surface. Measurement shall be made one hour or longer after cutting.

5.13 Tape Light Transmission.

5.13.1 Definition. Tape light transmission refers to the measure of light reflected by the mirror and transmitted through the plastic cover and tape.

5.13.2 Requirement. The tape shall have a light transmittance of less than 1% measured in a specular mode in a linear system by means of each of the following light sources when using a silicon photodiode for detection:

- (1) A tungsten lamp having a color temperature of 2000 +/- 200K
- (2) A light-emitting diode having a peak output at 940 +/- 50 nanometers

5.13.3 Procedure.

(1) Test Fixture. Tape light transmittance shall be measured using a tungsten lamp or light emitting diode light source and silicon photodiode for detection as shown in the set-up of Figure 12.

(2) Test Circuit. The measurement of transmittance shall be made using the test circuit shown in Figure 13, assuring that the photodiode is operating in the linear region (i.e. not saturated) when no tape is in place between aperture and mirror.

(3) Light Transmittance Measurement. The light transmittance shall be as follows:

$$\frac{E \text{ out (x 100 Range, Tape in Place)}}{E \text{ out (x 1 Range, No Tape)}} \times 100\%$$

The maximum light transmittance, as it applies to this standard, shall be the maximum value measured in the two zones: BOT to LP and EW to EOT . Note that the measurement includes all optical effects of the plastic cover and mirror.

6.0 TAPE RECORDING PROPERTIES.

The magnetic properties of the tape are defined by the testing requirements given in this section. When the tests are being performed, the output or resultant signal must be measured on the same relative pass for both the amplitude reference tape cartridge and the tape cartridge under test (read-while-write, or on equipment without read-while-write capability, on the first forward read pass) on the same equipment. Measurement

shall be made at a point in the read chain where the amplitude is directly proportional to the voltage generated in the read head.

All specifications in this section shall be met over the operating range of the cartridge. For comparison purposes to this standard, the cartridge shall be measured in the testing environment.

6.1 Defect Density.

6.1.1 Definitions.

defect density. The number of rejected regions observed, divided by the tested surface area is the defect density. It is expressed as defects per square inch (d/in^2) or defects per square millimeter (d/mm^2).

effective defect diameter (EDD). The EDD is computed as follows:

$$EDD = (1 - TL/100) \times TW$$

rejected region. Any head-to-tape separation, or anomaly in the oxide surface, which produces a loss of amplitude in the playback signal below TL is a missing pulse.

A rejected region is any 1.0 in (25.4 mm) length of test track containing one or more missing pulses.

tested surface area. The tested surface area is that surface containing recorded signals exclusive of erased gaps or other non-used recording areas where errors are not detectable.

This tested surface area is the product of TW and the total length of data track areas tested. The tested surface area must lie within the test recording area shown in Figure 2.

threshold level (TL). The TL is measured relative to the standard reference amplitude and is expressed as a percentage.

track width (TW). The TW is the width of recorded signal sensed by the read head.

6.1.2 Requirement. The defect density shall be less than, or equal to, 3 defects/ in^2 (0.0047 defects/ mm^2) for EDD=0.00225 in (0.057 mm).

6.1.3 Procedure. The test is performed in contact over the tested surface area at 50800 fpi (2000 ftpmm)

6.2 Average Signal Amplitude. The average peak-to-peak signal amplitude of the tape under test shall not deviate from the standard reference amplitude by more than

+/-25% at 50 800 ftpi (2000 ftpmm). The averaging shall be done over a minimum of 1.0 in (25.4 mm).

The tape under test and the amplitude reference tape cartridge shall be recorded on the same equipment using the test recording current. The output level shall be measured on a centrally located track on the same equipment.

6.3 Signal Decay

6.3.1 Definition. Signal decay is a measurement of loss in signal amplitude due to cycling a tape in contact.

6.3.2 Requirement. Signal decay shall not exceed 12% at 50 800 ftpi (2000 ftpmm) using procedure in 6.3.3.

6.3.3 Procedure. The tape under test is recorded at 50 800 ftpi (2000 ftpmm) using the test recording current. The tape is cycled from EOT to BOT to EOT 5 times noting the average peak-to-peak signal amplitude on the last forward pass. The tape is then cycled 50 additional times, noting the amplitude on the last forward cycle as above. Signal decay in percent is:

$$\frac{E_5 - E_{55}}{E_5} \times 100$$

6.4 Resolution. The resolution shall be between 80 and 120 percent of the resolution of the master standard reference tape. Traceability of the resolution of the master standard reference tape is provided by the calibration factors supplied with each secondary standard reference tape.

6.5 Typical Field. The typical field shall be between 80 and 120 percent of the reference field of the master standard reference tape. Traceability of the reference field is provided by the calibration factors supplied with each secondary standard reference tape.

7.0 MECHANICAL SPECIFICATIONS OF THE TAPE CARTRIDGE

7.1 General Description. The cartridge is a compact, coplanar design with the tape and hubs completely enclosed by the case, except for belt capstan and head openings. The drive is via a tensioned belt, which is driven by the internal belt capstan that receives motion from an external motor (see Figure 1.) Tape guides are located inside the cartridge. A transparent plastic top allows visual monitoring of the tape.

7.1.1 Dimension. The dimensions of the cartridge are as shown in Figure 5.

7.1.2 Mounting Position. The cartridge is intended to mount in read/write machines in one position only, and cartridges shall have asymmetrical features that can be utilized to prevent engaging the cartridge improperly (see Figure 5).

7.1.3 Cartridge Positioning Planes. The cartridge shall be referenced to the read/write machine only in the crosshatched areas shown in Figure 6. The application of forces suggested in Figure 6 is one method of assuring conformance of the cartridge to the positioning plane.

7.1.4 Attachment. The ends of the tape shall not be attached to the hubs.

7.1.5 Light Sense. The cartridge shall contain optical elements to permit photoelectric detection of the tape position holes. (see Figure 7).

7.1.6 Cartridge-in-Position Sense. The cartridge shall have an area on the front and side surfaces which is held to dimensions as shown in Figure 8 to be used for sensing that the cartridge is in position for writing and reading.

7.1.7 Cartridge Door. The cartridge shall have a door for protection of the tape during storage and transport. Requirements for opening the door are shown in Figure 9.

7.2 File Protect. The cartridge shall have an operator slide switch to prevent writing or erasing the tape. Devices using the cartridge shall be designed to prevent writing or erasing the tape when switch is positioned in the opposite direction of the "record" arrow. See Figure 8 for the file protect switch location. Color shall be grey.

7.3 Physical Labels.

7.3.1 Location and Size. The rear surface of the cartridge, opposite the exposed tape, and a portion of the top side of the cartridge may be used for labels. The rear surface area provides for readability of the label when it is in a stacked or inserted position. Position and size of the label shall be within the provided depression of the label area as shown in Figure 10.

7.3.2 Interchange Information. Suitable labels shall be used for marking contents of cartridges. The use of pencil or erasable material is not recommended.

7.4 Tape Guides. The tape shall be guided by tape guides contained within the cartridge (see Figure 11). The read/write machine shall not contain any elements to restrict the tape path in the transverse direction.

7.5 Speeds. The operating speed range for the cartridge tape is 22.6 in/s (0.58 m/s) to 120 in/s (3.05 m/s).

7.6 Driving Force. The tangential force required at the external driving surface of the belt capstan to maintain a constant operating speed shall be at least 1.0 ozf (0.28 N) at 22.6 in/s (0.58 m/s) but not more than 4.5 ozf (1.25 N) at 90 in/s (2.29 m/s) and 5.0 ozf (1.39 N) at 120 in/s (3.05 m/s), exclusive of motor drive puck effects. The external radial load applied to the belt capstan when making this measurement shall be 14.5 +/- 1.5 ozf (4.05 +/- 0.42 N). The measurement shall be taken when the cartridge is driven

at constant speed and a low friction contact surface (coefficient of friction < 0.1) located where the head would be located when the tape cartridge is inserted in a drive.

7.7 Total Inertia. The total equivalent inertial mass of all cartridge elements shall not exceed 0.0010 ozf-s²/in (10 g) referred to the outer surface of the belt capstan in linear units.

7.8 Dynamic Response.

7.8.1 Definition. Dynamic response refers to the velocity response of tape motion to a step driving function applied to the belt capstan.

7.8.2 Requirement. The natural resonant frequency shall be a minimum of 60 Hz.

7.8.3 Procedure. A drive capable of producing a pronounced overshoot of the tape velocity should be used. The drive servo should be critically damped so that the overshoot observed is not that of the drive. The reciprocal of the time measured between the first two overspeed peaks is the natural resonant frequency.

7.9 Tape Tension

7.9.1 Definitions

average tension. Average tension at a point along the length of the tape is the average value of the instantaneous tension measured over 3 ft (1 m) of tape symmetrically located around the point.

dynamic tension. Dynamic tension at a point along the length of the tape is the maximum variation of instantaneous tension over the 3 ft (1 m) length of tape symmetrically located around that point.

instantaneous tension. Instantaneous tension is the tension as measured at the cross section of the tape located at the head position of the free tape path and averaged over 10 msec. This value is the superposition of the average and dynamic tensions.

tape tension. Tape tension is the resultant force in the longitudinal direction of the tape on a cross section taken through the tape perpendicular to the longitudinal direction.

transverse tension variation. The transverse tension variation is that variation across the tape produced by differences in the free tape path length between the two edges of the tape.

7.9.2 Requirements.

7.9.2.1 Values of Instantaneous Tension

The instantaneous tension at any point along the length of tape between LP and EW shall be a minimum of 0.5ozf (0.14 N) and a maximum of 3.5 ozf (0.98 N).

7.9.2.2 Value of Dynamic Tension. The dynamic tension at any point along the length of the tape between LP and EW shall not exceed 0.50 ozf (0.14 N) (peak to peak).

7.9.2.3 Requirement for Transverse Tension Variation. The test rod shall not deviate from the horizontal by more than 1.5° at any point along the length of tape from LP to EW.

7.9.3 Procedures.

7.9.3.1 Procedures for Measuring Instantaneous Tension.

(1) Conditioning. Conditioning the tape before testing by winding from BOT to EOT and back to BOT.

(2) Tape Speed. The tape speed during testing shall be in accordance with 7.5.

(3) Position of the Measuring Transducer. The measuring transducer shall be positioned at the point along the free tape path at which the head would be located if the cartridge were mounted in a drive. When inserted in the tape path it shall cause an increase in the tape path length within the limits of 7.16. It shall be perpendicular to Reference Plane B within $\pm 1^{\circ}$.

(4) Characteristics of the Measuring Transducer. The coefficient of friction of the bearing surface shall be less than 0.1. The upper limit of its frequency response shall be at least 100 Hz. The width of the bearing surface shall be sufficient for it to be in contact with the whole width of the tape.

7.9.3.2 Procedure for Measuring Transverse Tape Tension Variation.

(1) Conditioning. Condition the tape before testing by winding from BOT to EOT, and back to BOT.

(2) Position of Tape for Measurement. The cartridge shall be held with Reference Plane B vertical and cartridge door on top and in the open position. The tape shall remain stationary at the selected point.

(3) Characteristics of the Test Rod. The form and dimensions of the test rod are given in Figure 14. The weight of the test rod shall be 0.5 oz. (14 g). The center of gravity shall be within 0.005 in (0.13 mm) of the center of notch.

(4) Position of the Test Rod. The slot of the test rod shall be centered over the point along the free tape path length at which the head would be located if the cartridge were mounted in a drive.

7.10 Drive Ratio. For constant rotation of the belt capstan, the ratio of the tape velocity to the surface velocity of the belt capstan shall be $0.78 + 0.00 - 0.02$.

7.11 Belt Capstan Electrical Resistance.

7.11.1 Definition: The electrical resistance of the belt capstan refers to the measurement of the bulk resistance of the belt capstan.

7.11.2 Requirement. The electrical resistance of the belt capstan shall not exceed 1 MOhm.

7.11.3 Procedure.

(1) Ensure that the contact surfaces of the belt capstan and the test fixture are clean and free from oil, grease, tarnish, or other contaminants before making the test. Refer to Figure 15.

(2) Place the belt capstan on the centering pin of the bottom contact surface, with the gate area over the relief.

(3) Place the upper contact surface on top of the belt capstan and apply a force of 6 lbf (26.6 N) centrally over the capstan.

(4) Measure the current flowing in the circuit when a potential of 500 +/- volts is applied.

7.11.4 Test Results. The current shall be 0.40 mA minimum.

7.12 Instantaneous Speed Variation (ISV).

7.12.1 Definition. Instantaneous Speed Variation is the variation of tape speed at the head, measured as a percentage of the nominal.

7.12.2 Requirements.

7.12.2.1 Low Frequency ISV. Within the band of zero to 1000 Hz the cartridge-induced ISV shall not exceed 4% (zero-peak). The measured ISV shall encompass discrete and combinations of frequency components within the band.

7.12.2.2 High Frequency ISV. Within the band from 1000 Hz to 50 kHz, there are two separate requirements.

(1) In a streaming mode test, the continuous ISV at the resonant frequency of the freespan to the tape shall not exceed 3% (zero-peak).

(2) In a shuffle mode or start/stop mode, the high frequency ISV shall not exceed 10% (zero-peak). The number of ISV events exceeding 5% (zero-peak) shall not exceed an average of one event per 10 shuffles or start/stop averaged over the length of tape.

7.12.3 Procedure.

7.12.3.1 General. Low frequency speed variations (analogous to wow) are the results of mechanical tolerances in the cartridge. Typical data-separator phase-locked loops have sufficient suppression at low frequencies that the residual time displacement error due to this component can be made negligible. High frequency speed variations (analogous to flutter) are the result of tension waves in the freespan length of tape between the hubs. In addition to the continuous component of this high frequency ISV at the resonant frequency of the fore freespan, occasionally a discrete event ISV occurs which exceeds the normal resonant background, but is damped back to it in a period of approximately one millisecond. These discrete events ISV can begin with either an underspeed or an overspeed pulse which is typically 80 microseconds wide. Underspeed events are most commonly associated with a tape direction reversal or a start/stop cycle of the cartridge.

7.12.3.2 Test Circuit. A standard tester is a modulation analyzer (e.g. HP8901) tuned to the frequency of the carrier. The output of an FM demodulator is filtered to select the low frequency ISV or the high frequency ISV characteristics.

7.12.3.3 Test Method.

(1) Record the tape at constant density with a record frequency not less than 200 kHz.

(2) Read the tape signals at the same tape speed used to write them, using a square wave output from the read channel connected to the input of the test circuit.

(3) In the streaming mode, measure the amplitude of the low frequency and high frequency components of the ISV.

(4) In start-stop or shuffle mode, record the occurrence of any isolated events in which the high frequency ISV exceeds 5% (zero-peak), excluding events caused by missing pulse and analyzer settling at ramp-up or ramp-down.

(5) Events which occur within 1.0 ms. shall be considered a single event.

7.13. Acceleration. Change in the cartridge tape speed.

7.13.1 The cartridge shall be capable of withstanding acceleration and deceleration of 1000 in/sec^2 (25.4 m/sec^2) of the linear tape speed.

7.13.2 The maximum rate of change of acceleration shall be no more than $80\,000 \text{ in/sec}^3$ (2032 m/sec^3).

7.14 Dynamic Tape Skew

7.14.1 Definition. Dynamic tape skew is the variation of the angle that the centerline of the tape makes with Reference Plane B.

7.14.2 Requirement. The dynamic tape skew shall not exceed 5 minutes of arc.

7.14.3 Procedure. Write flux transitions on two test tracks over the entire recording area of the tape at speed v .

Using the same two gaps, read the tape in the forward and reverse directions, measuring the time difference between corresponding flux transitions.

The maximum time difference t and the distance d between the centerline of the two test tracks are used to calculate the dynamic tape skew, namely: $\arctan(t \times v/d) \leq 5'$.

7.15 Drop Test. The cartridge shall be able to withstand the shock incurred from falling 30 in (0.76 m) onto a concrete floor covered with asphalt tile. The cartridge shall be dropped once on one corner and once on the base. After the drops, the cartridge shall then meet all the requirements of this standard.

7.16 Head Penetration

7.16.1 Definition. Head penetration is the increase in tape path length resulting from the deviation of the tape path from a straight line caused by the recording head (s) or other drive components when the cartridge is inserted in a drive.

7.16.2 Recommendation. To assure reliable tape handling and to avoid tape damage, the head penetration should be greater than 0.005 in (0.13 mm) and less than 0.040 in (1.02 mm).

7.17 Dynamic Track Movement Variation. The dynamic track movement variation is that variation of tape track movement which is perpendicular to the direction of tape motion. The variation shall not exceed +/- 0.0005 in (+/- 0.013 mm) from the first write pass (BOT to EOT to BOT) after the cartridge has been conditioned. The variation in the opposite direction from the first write pass shall not exceed +/- 0.001 in (+/- 0.025 mm).

7.18 Tape Slope. The tape slope is defined as the average slope measured within the head area at a period ≥ 9 in (229 mm) of the tape edge relative to the -B- plane, excluding tape width and weave variations, from BOT to EOT or EOT to BOT. The tape slope shall be $\leq .003$ in/in.

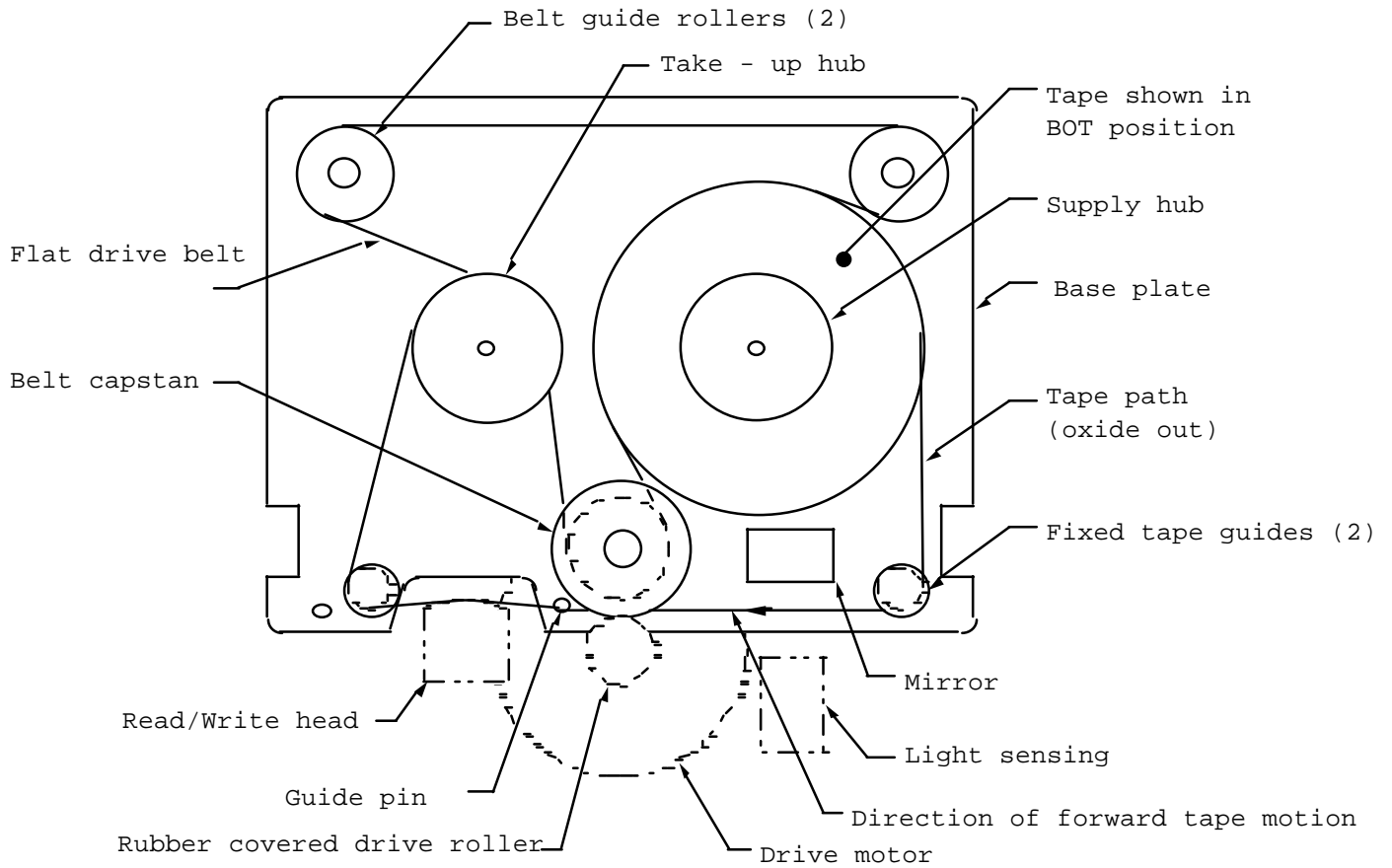
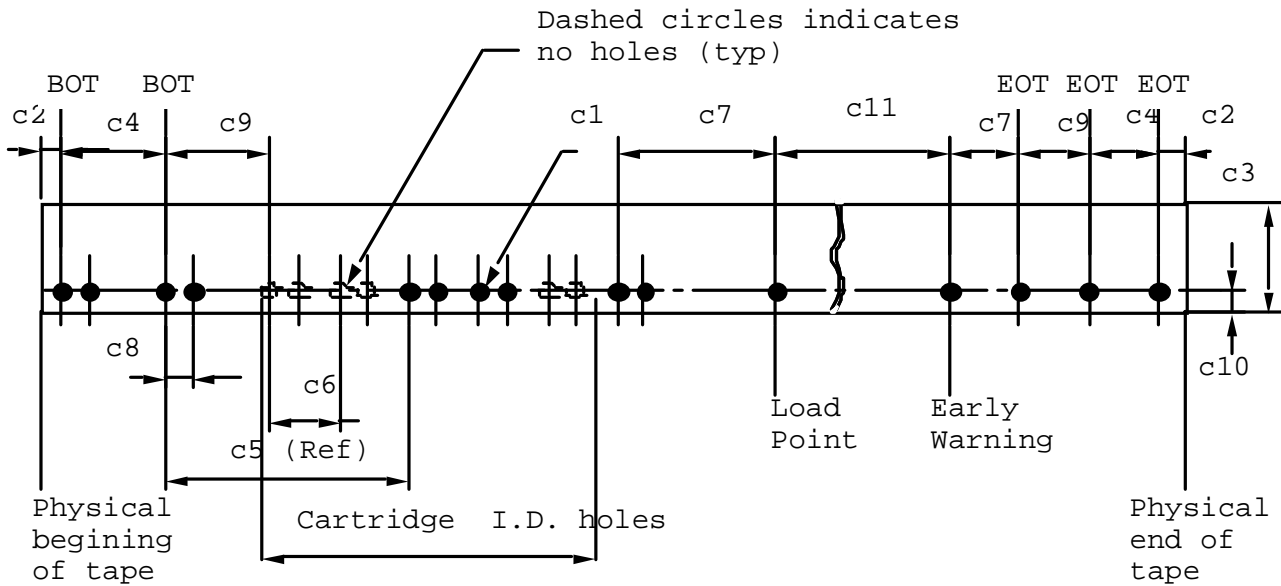

Figure 1 - Possible cartridge configuration



Dimension	Inches	Millimeters
c1(15x)Diameter	0.046+/-0.002	1.17+/-0.005
c2(2x)(Minimun)	12	305
c3	0.3150+/-0.0005	8.000+/-0.013
c4(2x)	12+/-1	305+/-25
c5(Ref)	20+/-0.3	508+/-7.6
c6(5x)	2.5+/-0.3	63.5+/-7.6
c7(2x)	24+/-1	610+/-25
c8(5x)	0.218+/-0.010	5.54+/-0.25
c9(2x)	15+/-1	380+/-25
c10	0.075+/-0.004	1.90+/-0.10
	<u>Feet</u>	<u>Meters</u>
c11	400±25/-0	121.9±8.0/-0

Code	Binary	Conversion
octal 06		X00,110

NOTES:

1. Cartridge I.D.hole pattern is decoded least significant bit first (LSB) with respect to load point.

Figure 2 - Tape position hole

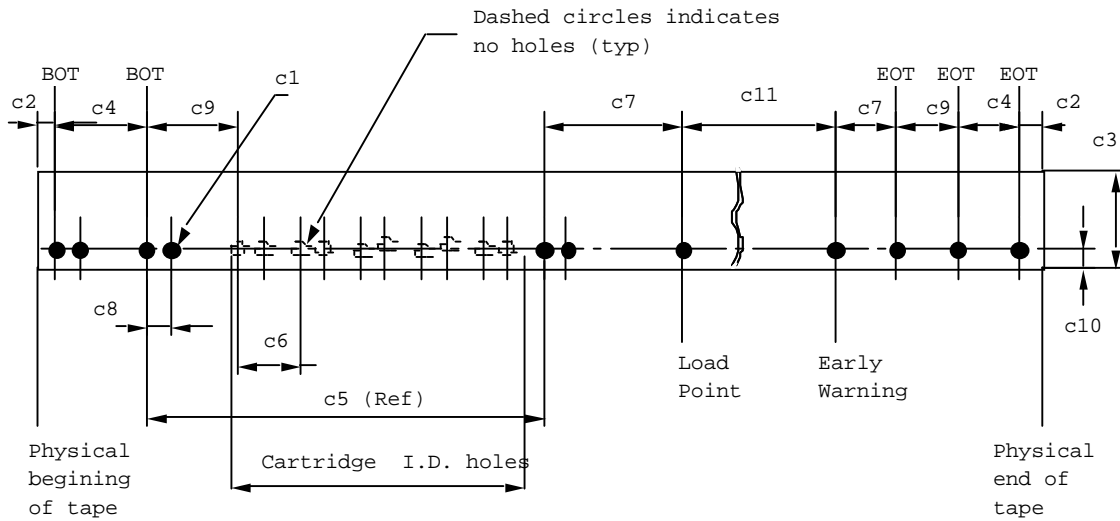

Dimension	Inches	Millimeters
c1(11x)Diameter	0.046+/-0.002	1.17+/-0.005
c2(2x)(Minimum)	12	305
c3	0.3150+/-0.0005	8.000+/-0.013
c4(2x)	12+/-1	305+/-25
c5(Ref)	30.5+/-0.3	775+/-7.6
c6(5x)	2.5+/-0.3	63.5+/-7.6
c7(2x)	72+/-1	1829+/-25
c8(5x)	0.218+/-0.010	5.54+/-0.25
c9(2x)	18+/-1	457+/-25
c10	0.075+/-0.004	1.90+/-0.10
	<u>Feet</u>	<u>Meters</u>
c11	400 +25/-0	121.9 +8.0/-0

Code	Binary Conversion
octal 00	X00,000

NOTES:

1. Cartridge I.D. hole pattern is decoded least significant bit first (LSB) with respect to load point.

Figure 2A - Tape position hole

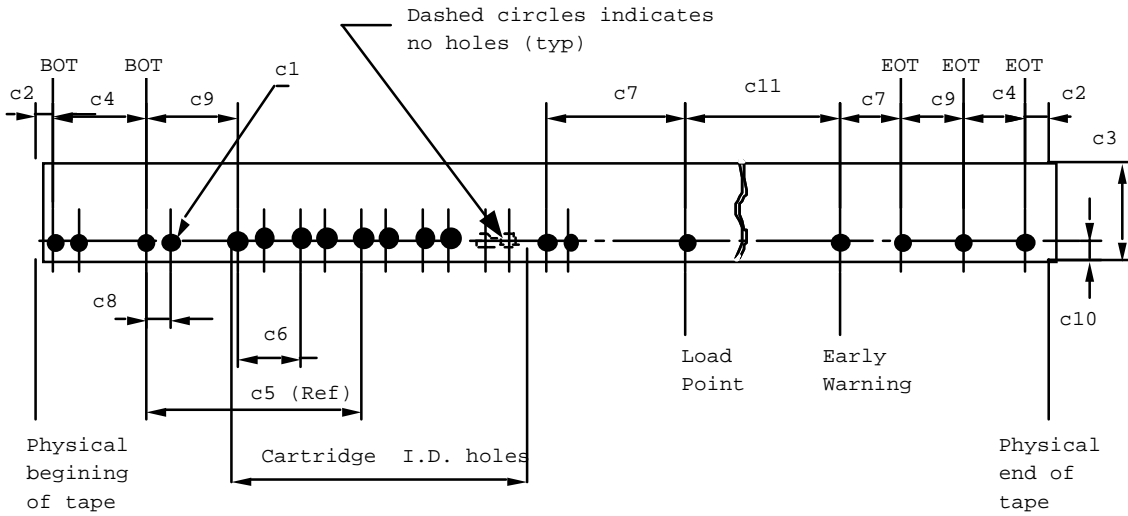

Dimension	Inches	Millimeters
c1 (19x) Diameter	0.046+/-0.002	1.17+/-0.005
c2 (2x) (Minimum)	12	305
c3	0.3150+/-0.0005	8.000+/-0.013
c4 (2x)	12+/-1	305+/-25
c5 (Ref)	20.0+/-0.3	508+/-7.6
c6 (5x)	2.5+/-0.3	63.5+/-7.6
c7 (2x)	144+/-3	3658+/-76
c8 (5x)	0.218+/-0.010	5.54+/-0.25
c9 (2x)	15+/-1	380+/-25
c10	0.075+/-0.004	1.90+/-0.10
	<u>Feet</u>	<u>Meters</u>
c11	400+25/-0	121.9+8.0/-0

Code	Binary	Conversion
octal 36		X11,110

NOTES:

1. Cartridge I.D. hole pattern is decoded least significant bit first (LSB) with respect to load point.

Figure 2B - Tape position hole

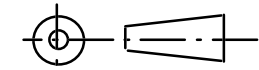
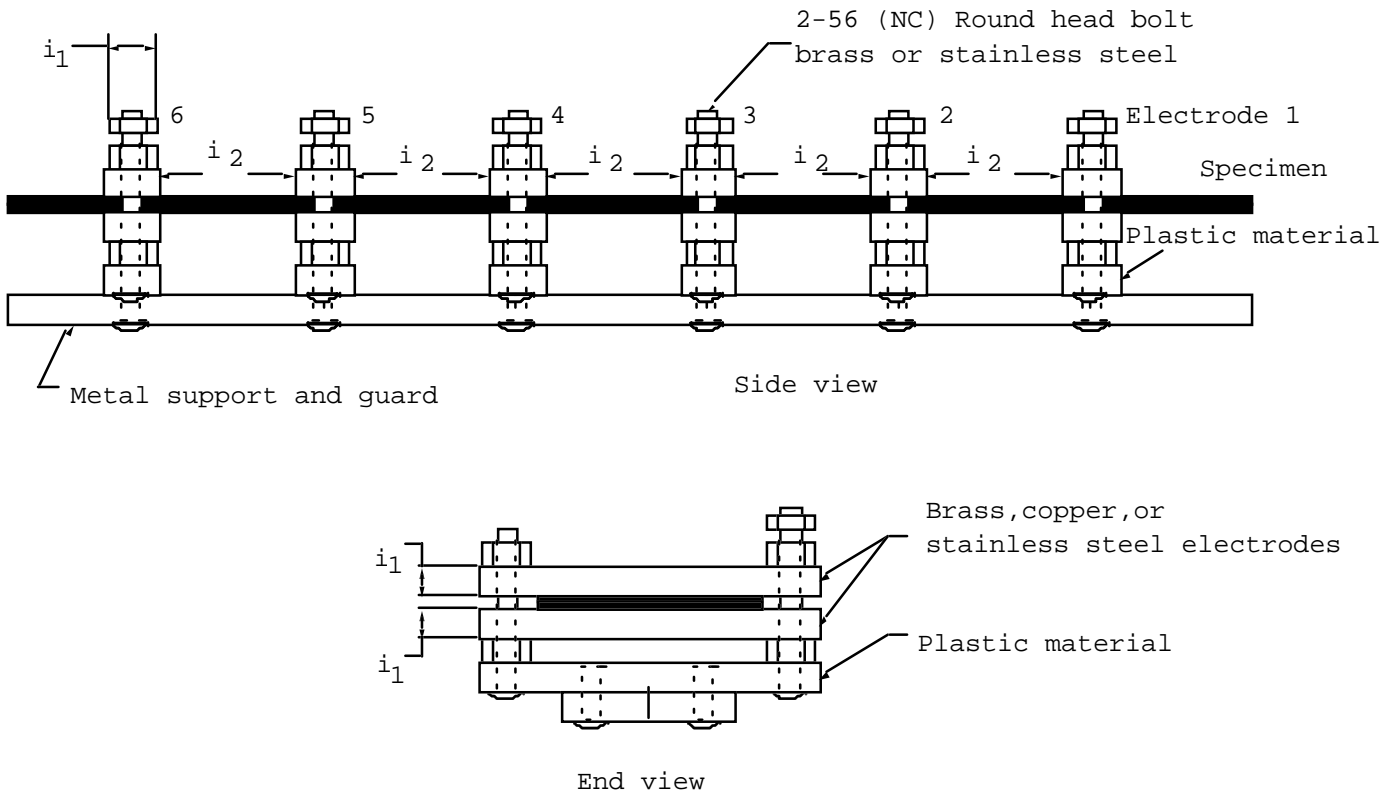

Third Angle Projection

Dimension	Inches	Millimeters
i_1 (Typ)	0.250	6.35
i_2 (Typ)	0.500	12.70

Figure 3 - Tape resistance measurement electrodes

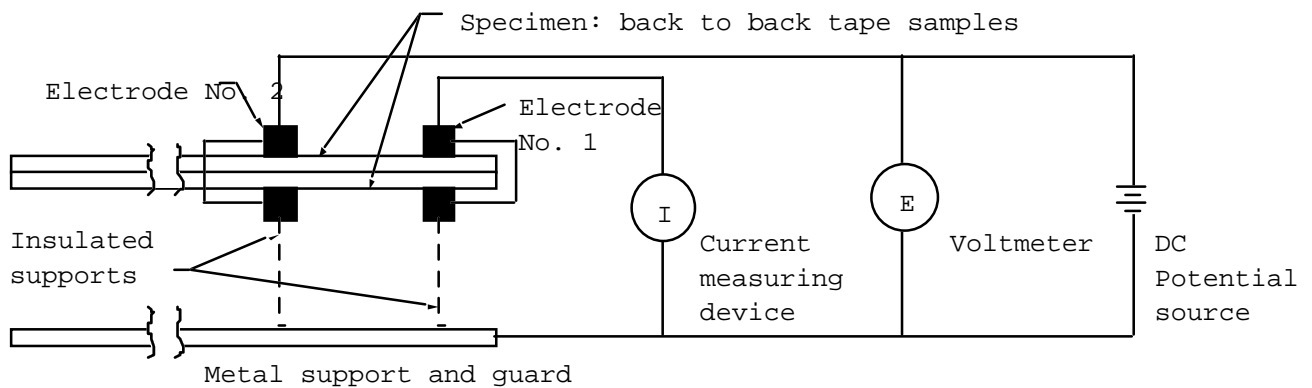
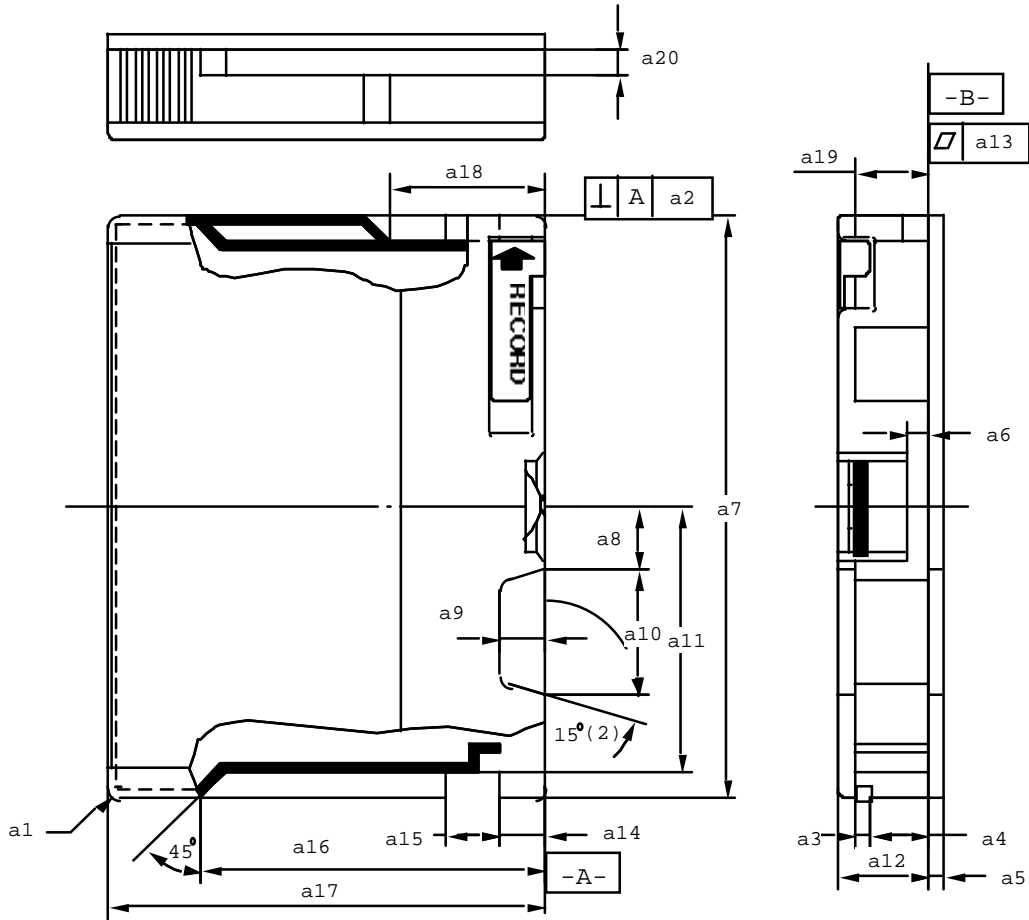

Figure 4 - Tape resistance measurement circuit



NOTE:

1. All tolerances except where otherwise noted are +/- 0.005in(+/-0.13mm), <0.5deg.
2. Features required to prevent inserting cartridge improperly.
3. Cover (top edge) may extend beyond base 0.010in (0.25mm) maximum, all sides at notches.
4. Features identified by dimensions a18 and a20 are intended to physically prevent the insertion of this cartridge into drives designed only for 0.250 inch (6.3mm) tape width. It is recommended that drive designers utilize these features to prevent the insertion of the 0.315in (8.0mm) wide tape into drives that are only intended for use with 0.25in (6.3mm) tape width.

Dimension	Inches	Millimeters
a1(6x)(Radius)	0.062	1.57
a2	0.005	0.13
a3	0.066	1.68
a4	0.334	8.48
a5(Base mat'l thk)	0.080+0.003/-0.005	2.03+0.08/-0.13
a6	0.125+/-0.010	3.18+/-0.25
a7	3.188	80.98
a8	0.344	8.74
a9	0.250	6.35
a10	0.687	17.45
a11	1.454	36.93
a12(Maximum)	0.500	12.70
a13	0.005	0.13
a14	0.250	6.35
a15(two places)	0.312	7.92
a16	1.906+/-0.010	48.41+/-0.25
a17	2.406	61.11
a18	0.860+/-0.010	21.84+/-0.25
a19	0.400	10.16
a20	0.140+/-0.010	3.56+/-0.25

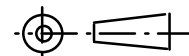

Third Angle Projection

Figure 5 - Cartridge Dimensions

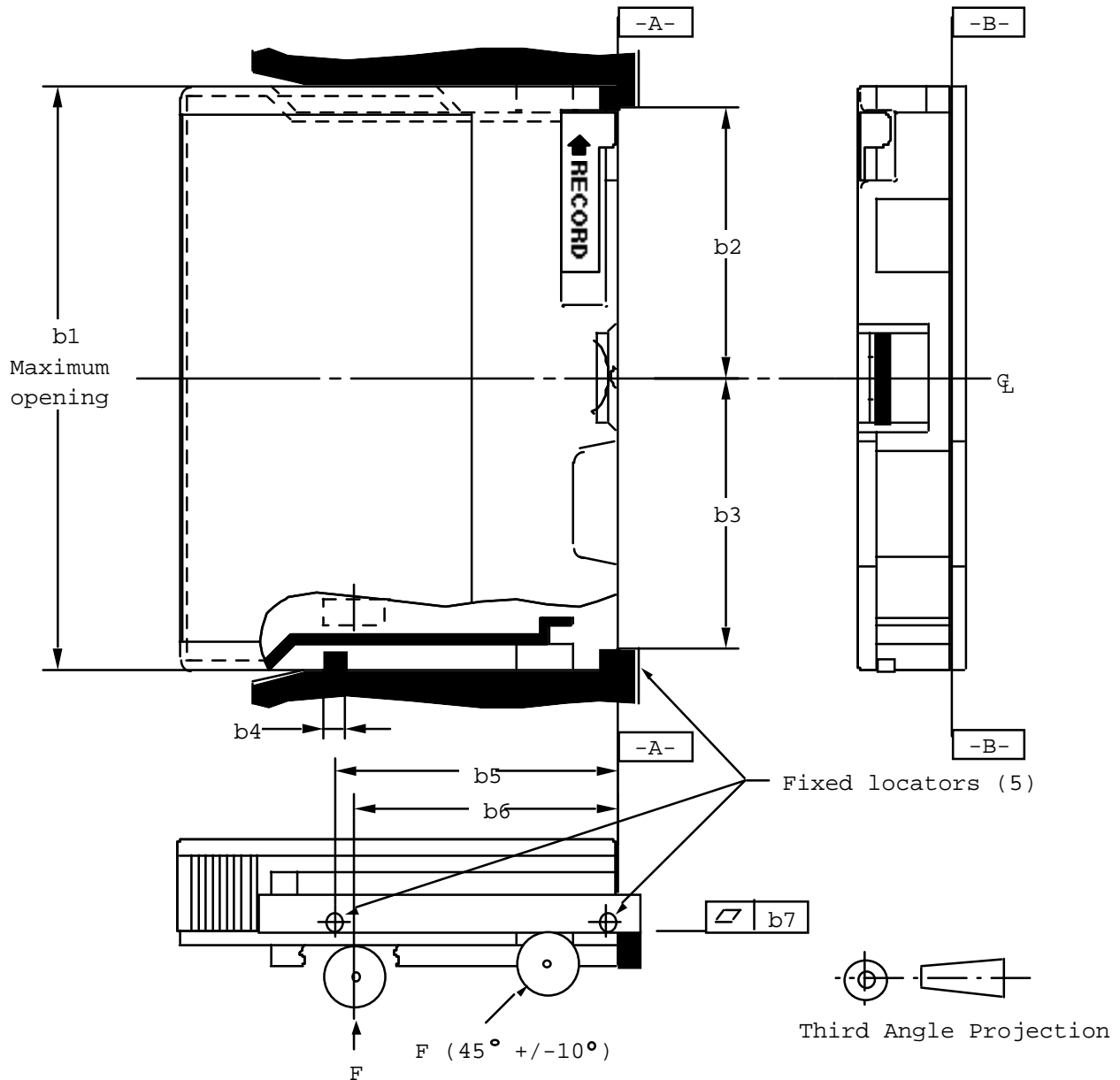

NOTE:

1. All tolerances except where otherwise noted are ± 0.005 in (± 0.13 mm).
2. Fixed locators (2X) along surface $-A-$ defined as datum $-A-$.
3. $b_4(3X)$ indicates cartridge plane locations defined as datum $-B-$.

Dimension	Inches	Millimeters
b_1	3.210	81.53
b_2	1.480	37.59
b_3	1.480	37.59
b_4 (3X)	0.200	5.08
b_5	1.525	38.74
b_6	1.344	34.13
b_7	0.005	0.13

Figure 6 - Cartridge locating planes

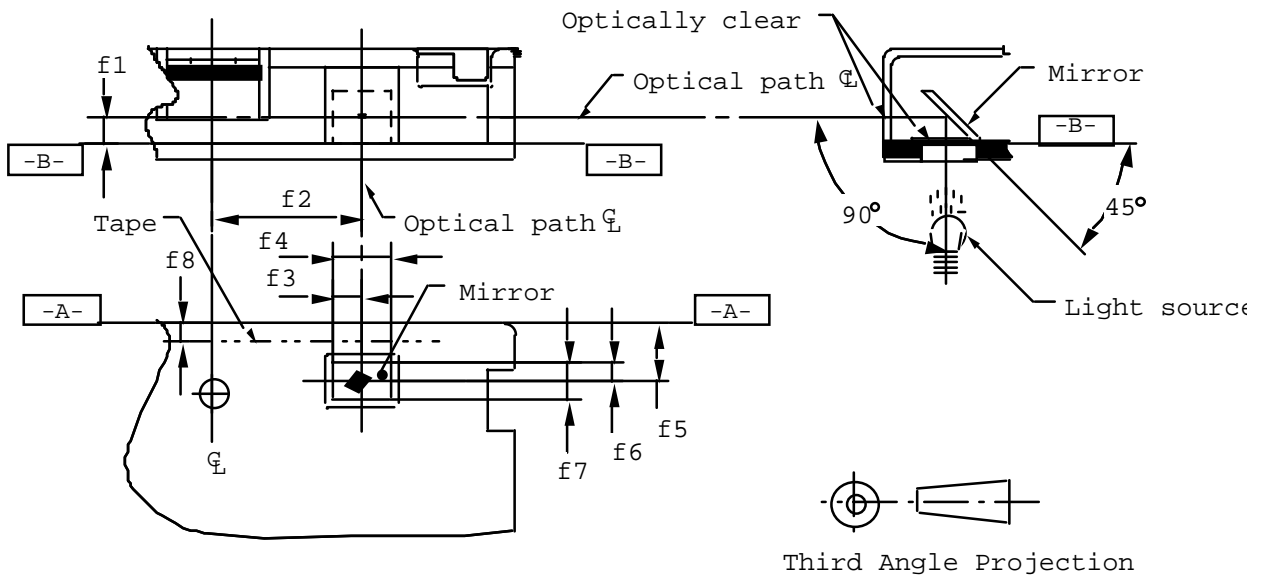
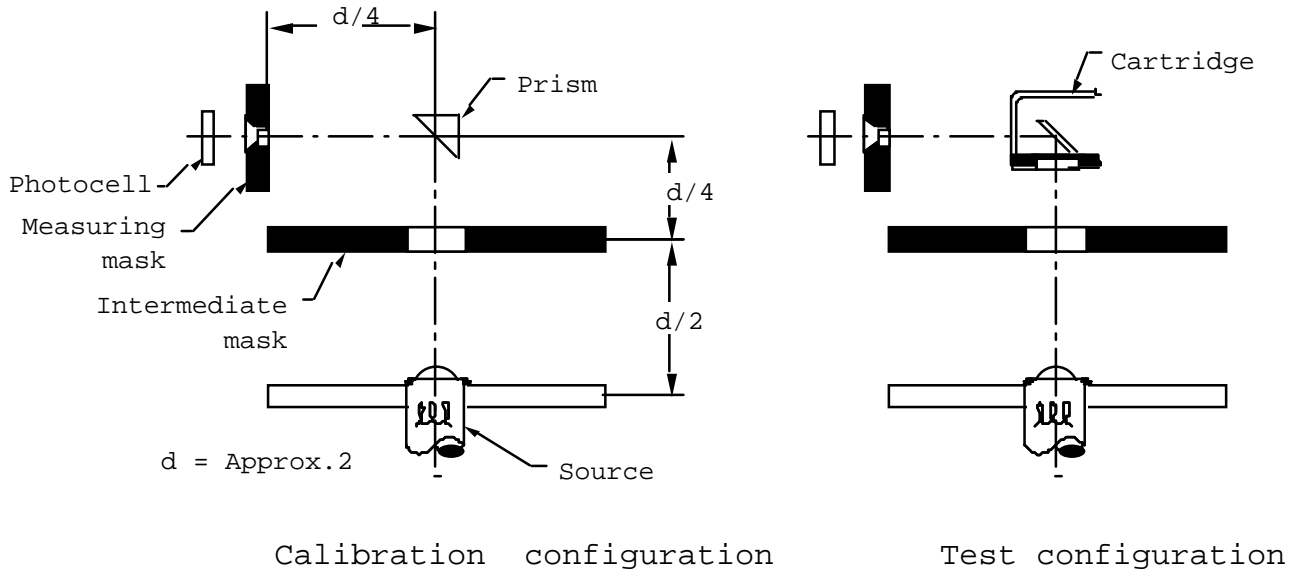

NOTE:

1. All tolerances except where otherwise noted are +/-0.005in (+/-0.13mm).
2. Optical paths perpendicular to -B- plane reflected by the mirror at 90 degree through the tape position holes at f1.f2.shall not deviate from 90 degree by more than +/-3degree in all directions.
3. Total optical transmission of both cover windows(including effects of reflection off mirror surface) to each of the following light sources shall be 50% minimum when sensed by a photo cell:

Dimension	Inches	Millimeters
f ₁	0.120	3.05
f ₂	0.781	19.84
f ₃	0.160+/-0.011	4.17+/-0.28
f ₄	0.328+/-0.021	8.33+/-0.53
f ₅	0.332	8.43
f ₆	0.085+/-0.010	2.16+/-0.25
f ₇	0.170+/-0.020	4.32+/-0.51
f ₈	0.095+/-0.007	2.41+/-0.18

Figure 7 - Light sensing

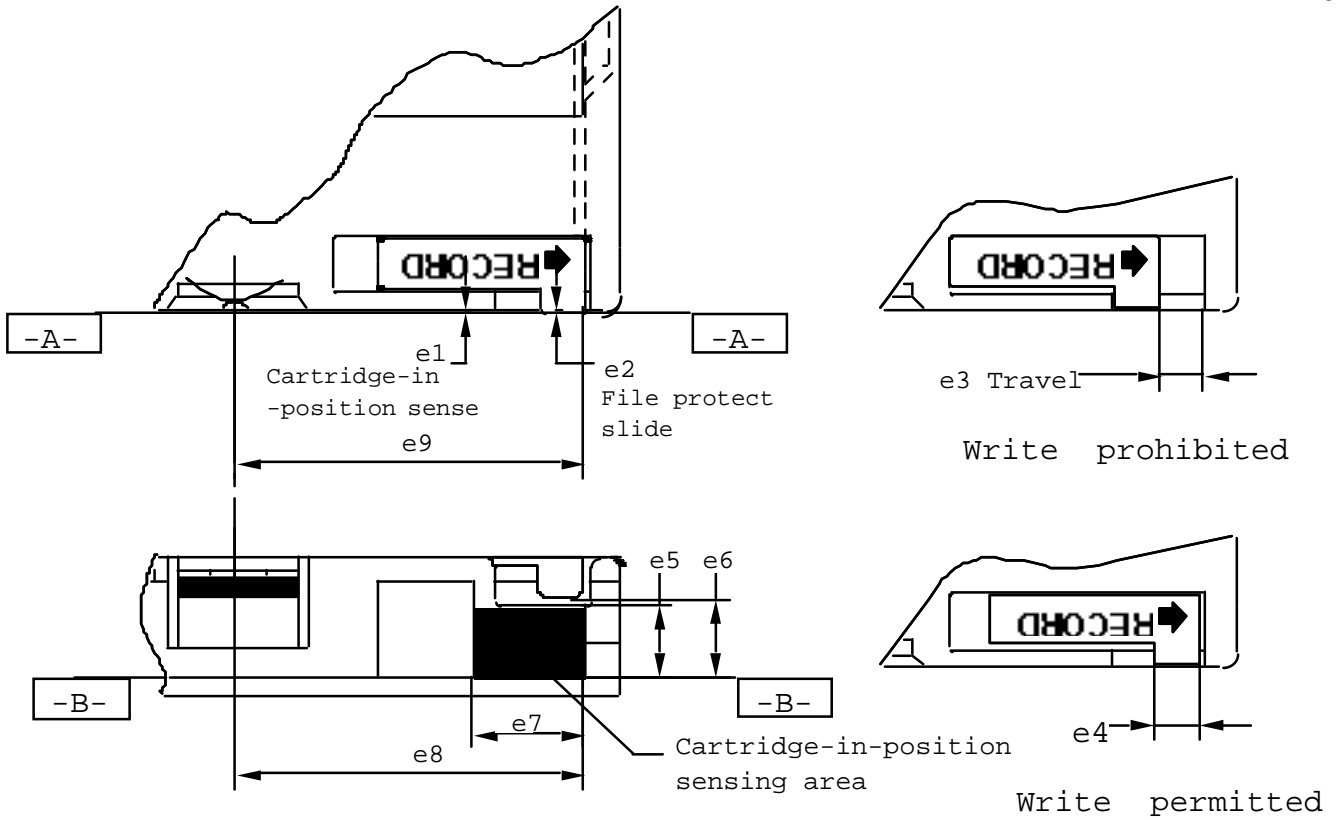

NOTE:

1. All tolerances except where otherwise noted are ± 0.005 in (± 0.13 mm).

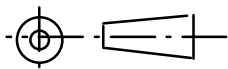

Third Angle Projection

Dimension	Inches	Millimeters
e ₁	0.000 \pm 0.010	0.00 \pm 0.25
e ₂	0.000 \pm 0.010	0.00 \pm 0.25
e ₃	0.150 \pm 0.010	3.81 \pm 0.25
e ₄	0.190	4.83
e ₅	0.300	7.62
e ₆	0.305 ^{+0.010} /-0.000	7.75 ^{+0.25} / _{-0.00}
e ₇	0.473 \pm 0.010	12.01 \pm 0.25
e ₈	1.450 \pm 0.010	36.83 \pm 0.25
e ₉	1.450 \pm 0.020	36.83 \pm 0.51

Figure 8 - File protect and cartridge-in-position sense

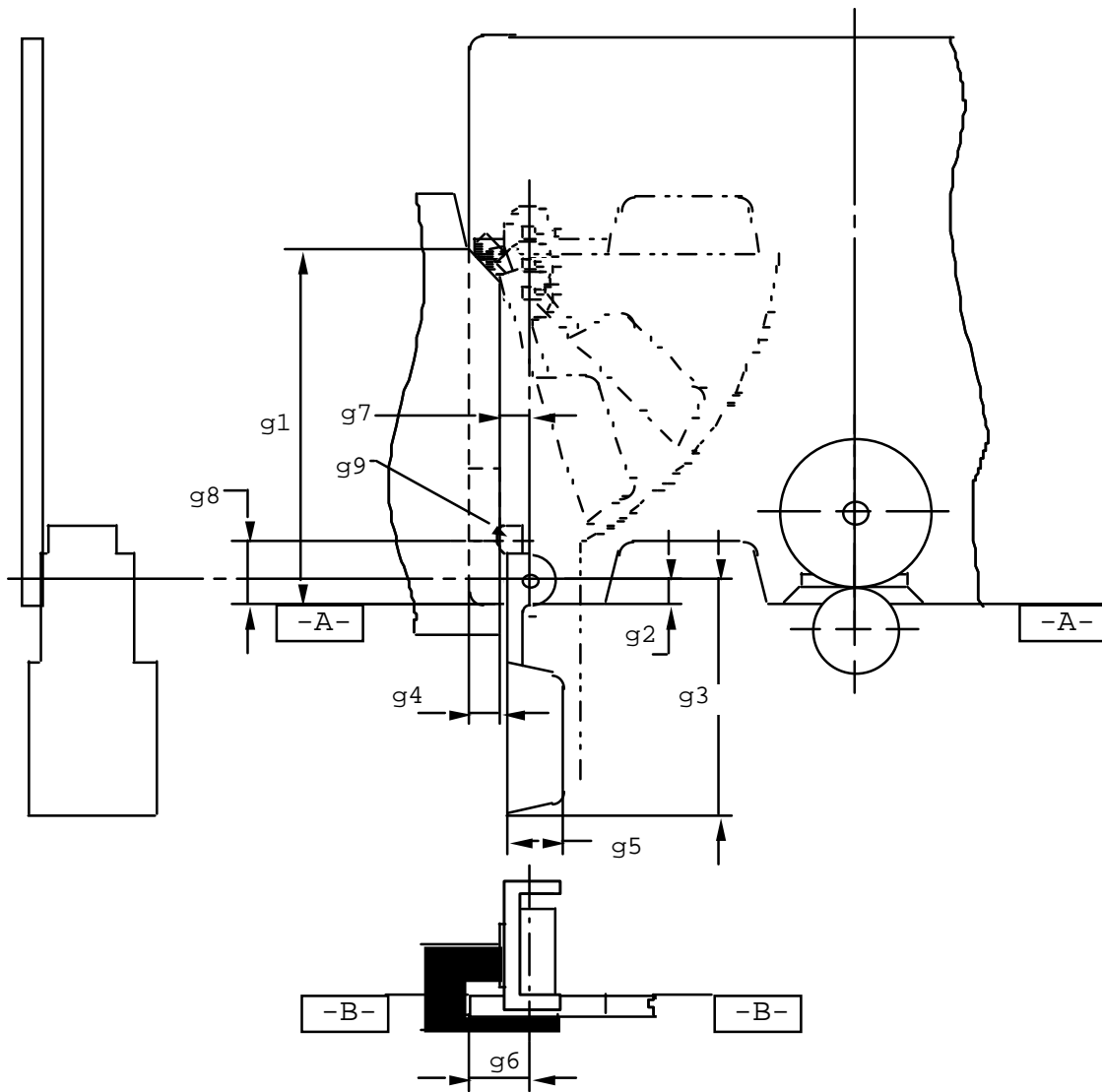

NOTE:

1. All tolerances except where otherwise noted are ± 0.005 in (± 0.13 mm).

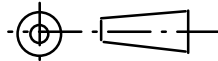

Third Angle Projection

Dimension	Inches	Millimeters
g1 (Minimum)	1.250	31.75
g2	0.100	2.54
g3*	$1.000 + 0.005 / -0.010$	$25.40 + 0.13 / -0.25$
g4	0.125	3.18
g5*	$0.250 + 0.005 / -0.010$	$6.35 + 0.13 / -0.25$
g6	0.241	6.12
g7*	0.115	2.92
g8*	0.161	4.09
g9* (Radius)	0.093	2.36

* Door dimension

Figure 9 -Cartridge door profile

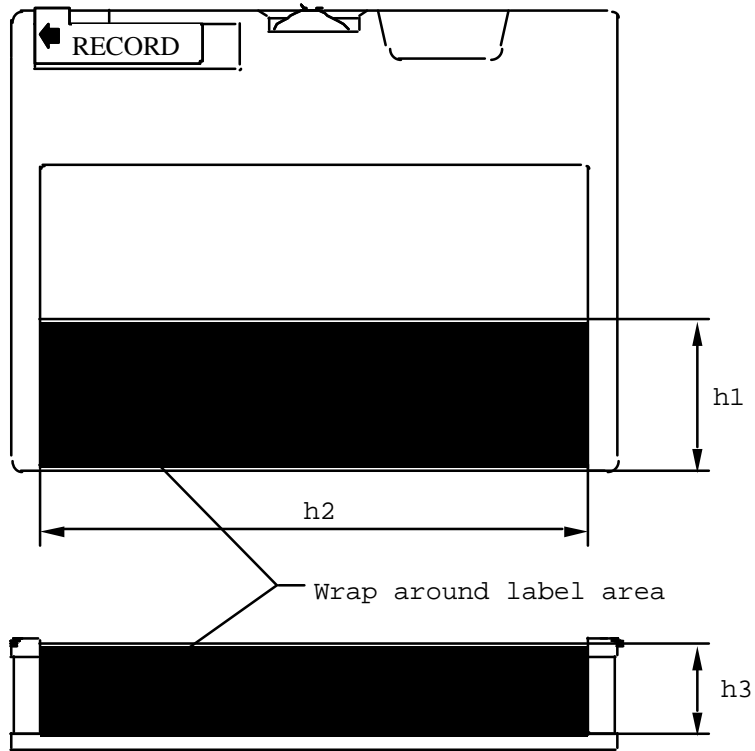

NOTE:
1. All tolerances except where otherwise noted are +/-0.005in (+/-0.13mm).

Dimension	Inches	Millimeters
h_1	0.625	15.88
h_2	2.875	73.02
h_3	0.437	11.10

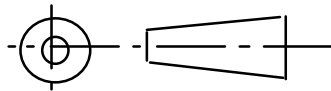
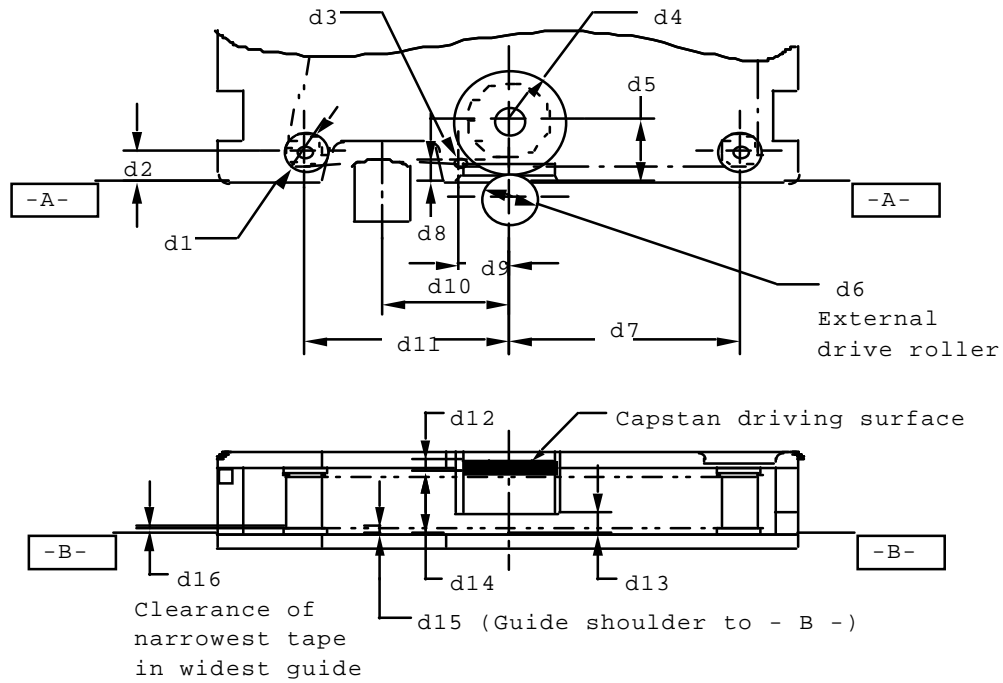
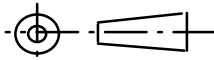

Figure 10 - Label area



NOTE:

1. All tolerances except where otherwise noted are +/-0.005in (+/-0.13mm).



Third Angle Projection

Dimension	Inches	Millimeters
d ₁ (Diameter)	0.187	4.75
d ₂	0.188	4.78
d ₃ (Diameter)	0.062	1.57
d ₄ (Radius)	0.312	7.92
d ₅	0.375	9.52
d ₆ (Max diameter)	0.875	22.22
d ₇	1.272	32.31
d ₈	0.125	3.18
d ₉	0.273	6.93
d ₁₀	0.700	17.78
d ₁₁	1.125	28.58
d ₁₂	0.073	1.85
d ₁₃	0.125	3.18
d ₁₄	0.378 +/- 0.010	9.6 +/- 0.25
d ₁₅	0.045 +/- 0.0015	1.14 +/- 0.04
d ₁₆ (Maximum)	0.0018	0.046

Figure 11-Tape path and drive dimensions

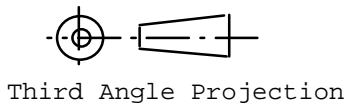
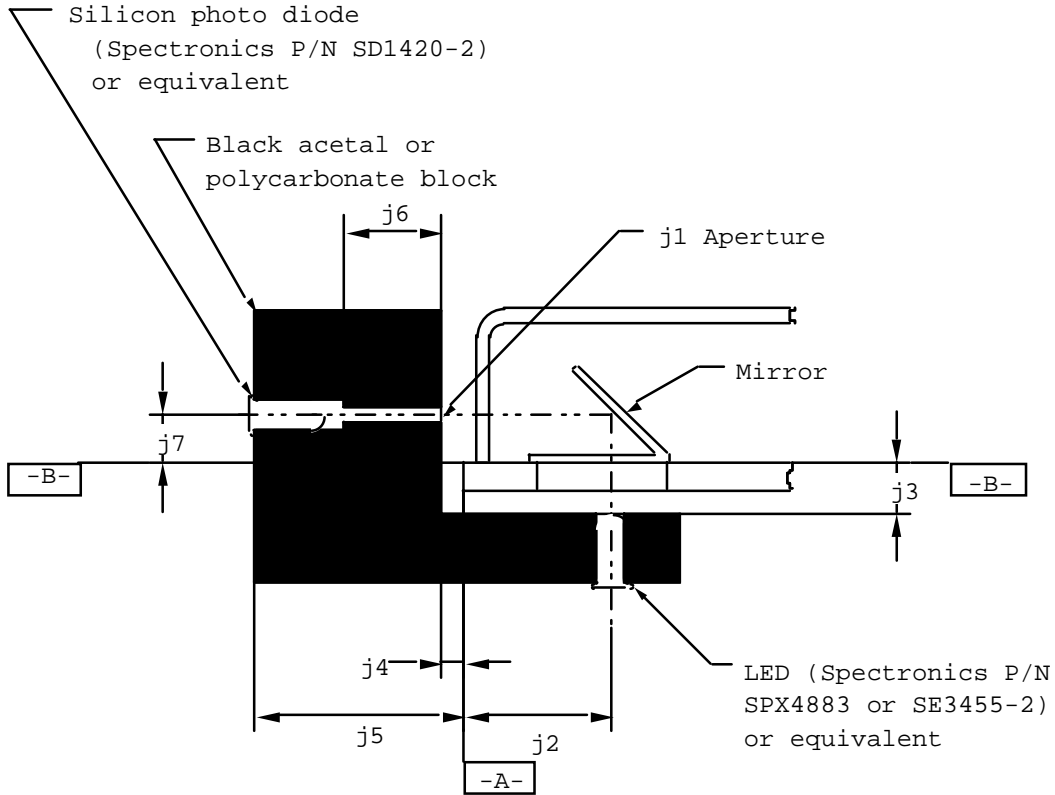

Dimension	Inches	Millimeters
j ₁ (Diameter)	0.080 \pm 0.002	2.03 \pm 0.05
j ₂	0.332	8.43
j ₃	0.110	2.79
j ₄	0.050	1.27
j ₅	0.450	11.43
j ₆	0.200	5.08
j ₇	0.120	3.05

NOTE:

1. All tolerances except where otherwise noted are ± 0.005 in (± 0.13 mm).

Figure 12 - Tape light transmission test fixture

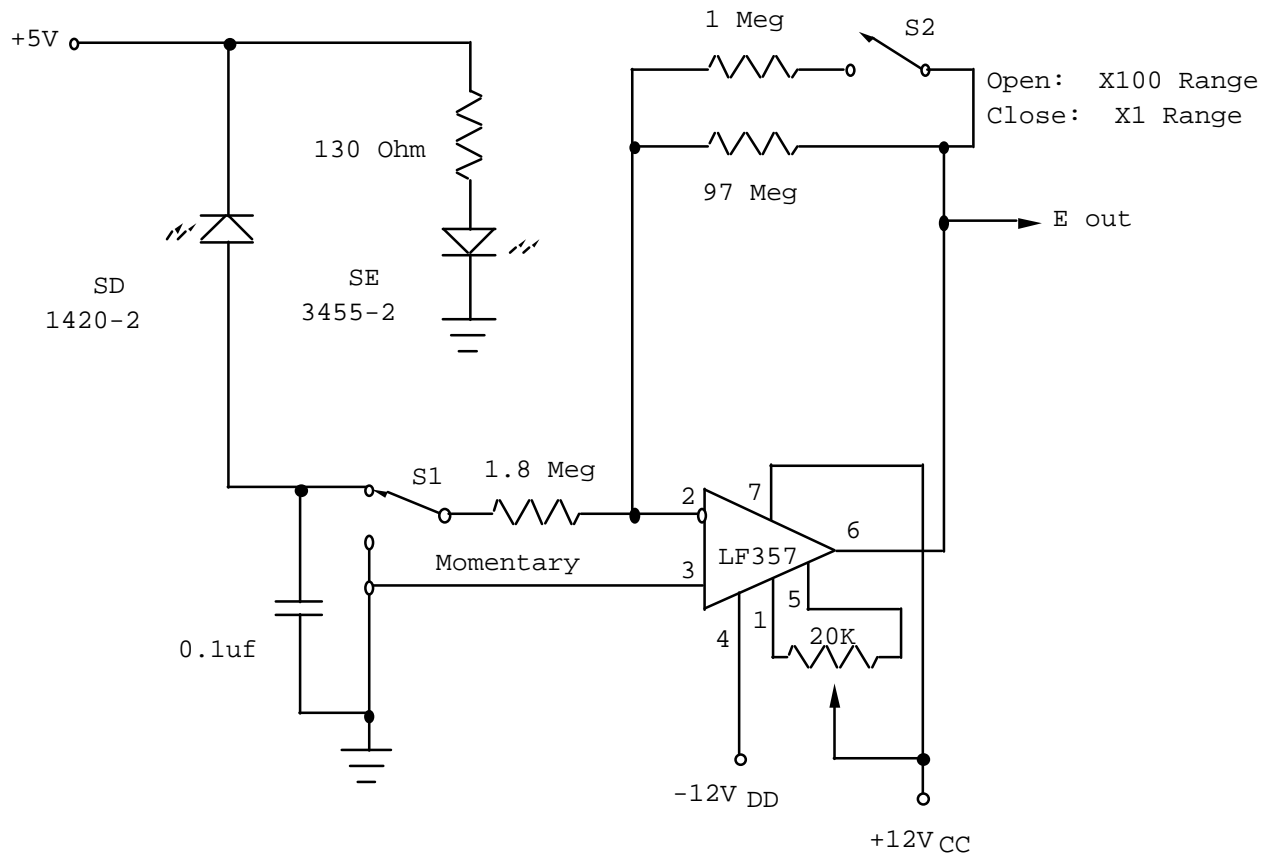
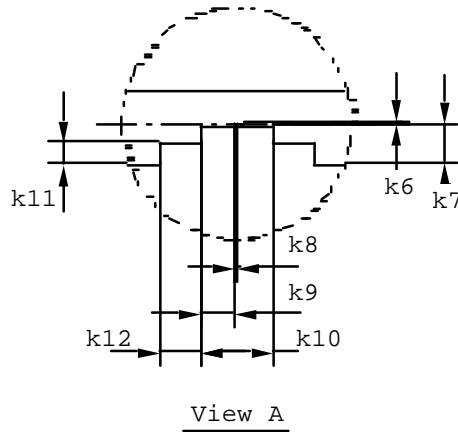
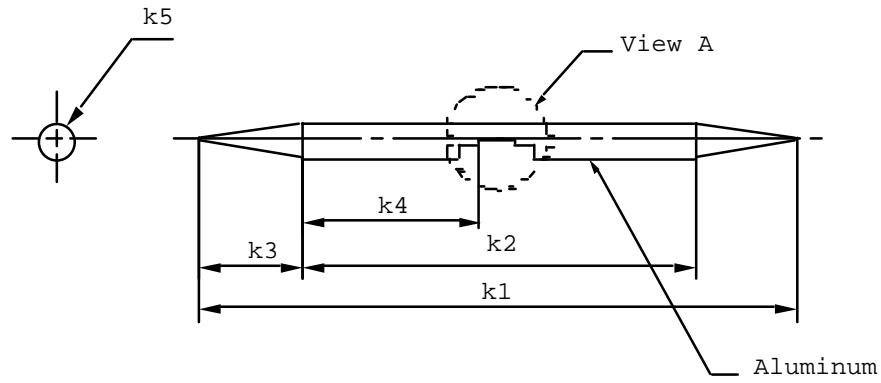
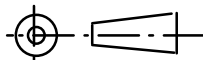

Figure 13 - Tape light transmission test circuit



NOTE:

1. All tolerances except where otherwise noted are ± 0.005 in (± 0.13 mm), < 0.5 degree.
2. When notch is placed on a level edge 0.009 ± 0.001 (0.229 \pm 0.025 mm) in wide, bar shall balance with no noticeable lean.



Third Angle
Projection

Dimension	Inche	Millimeters
k ₁	5.450	138.43
k ₂	3.574	90.78
k ₃	0.938	23.82
k ₄	1.628	41.35
k ₅ (Diameter)	0.312	7.92
k ₆	0.010	0.25
k ₇	0.156	3.96
k ₈	0.011 \pm 0.001	0.279 \pm 0.003
k ₉	0.153 \pm 0.001	3.885 \pm 0.003
k ₁₀	0.317 \pm 0.001	8.05 \pm 0.025
k ₁₁	0.125	3.18
k ₁₂ (X2)	0.250	6.35

Figure 14 - Transverse tape tension test rod

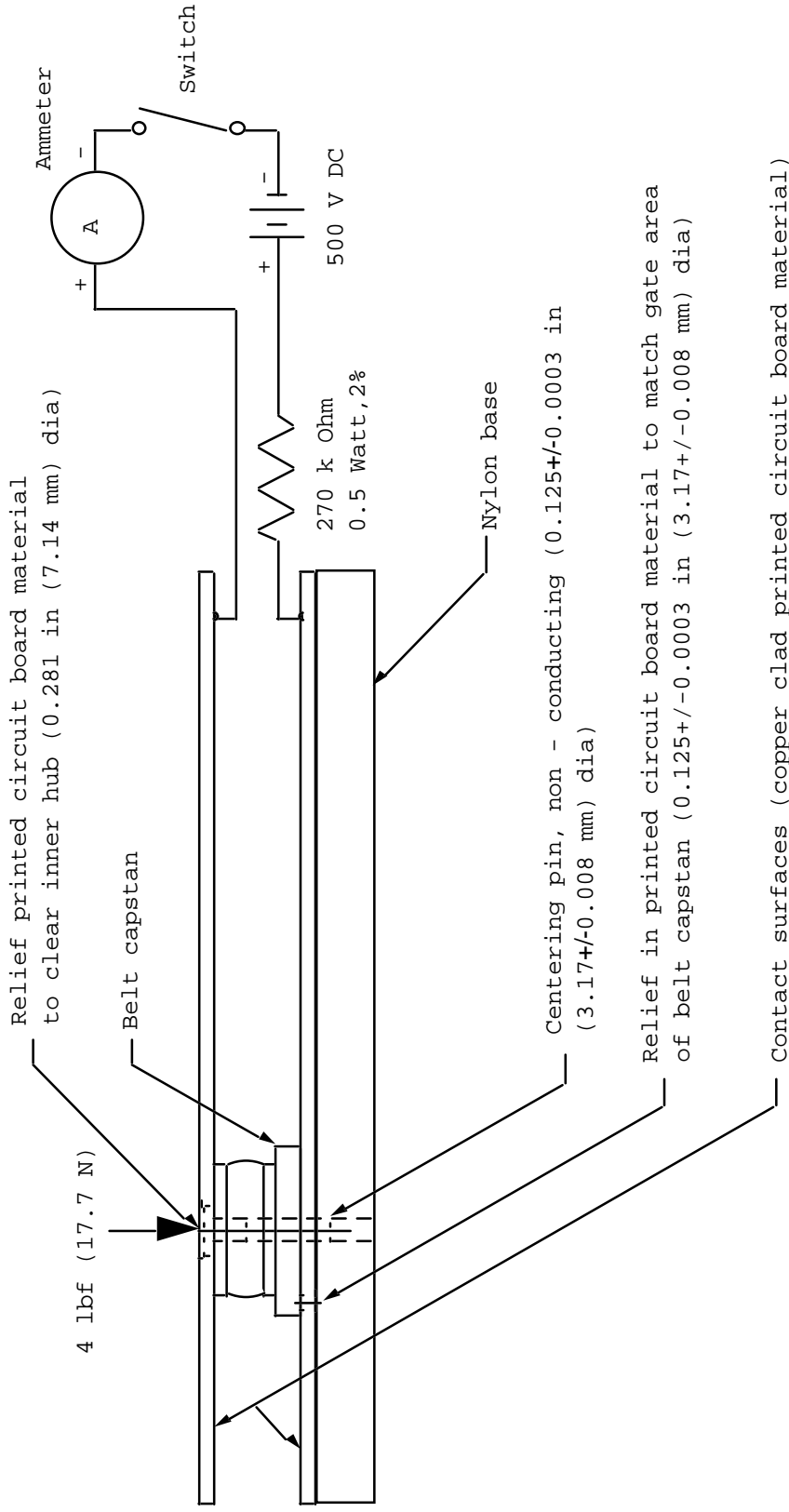

NOTE : All tolerances except where otherwise noted are +/- 0.005 in (+/- 0.13 mm).

Figure 15 - Belt capstan electrical resistance test fixture